

Quick Start Guide

Flo-Link™ Pressurized Panel Mount Flow Center



BOSCH

Flo-Link™ is a trademark of Geo-Flo Products Corporation, Bedford, IN, U.S.A. The panel mount flow center is a self-contained package, designed to significantly reduce installation time for variable speed flow centers. All components necessary for plumbing and controlling the pump are included. *Please read this quick start guide in its entirety before attempting to install the flow center.*

1. Verify package contents. Included in the package is the panel/flow center/controller, as well as all of the fittings needed for connecting to the ground loop and heat pump (Figure 1).



Figure 1: Package contents

2. Complete ground loop piping. The package includes one set of 1-1/4" PE fusion by Flow-Link™ double O-ring fittings. It's generally easier to fuse the fittings to the pipe first, making sure that the two fittings are even. Then, mount the panel to the wall, so that the fittings are at the correct depth, and not angled. The flow center should be installed as close to the heat pump as possible, so that excessive hose is not needed.

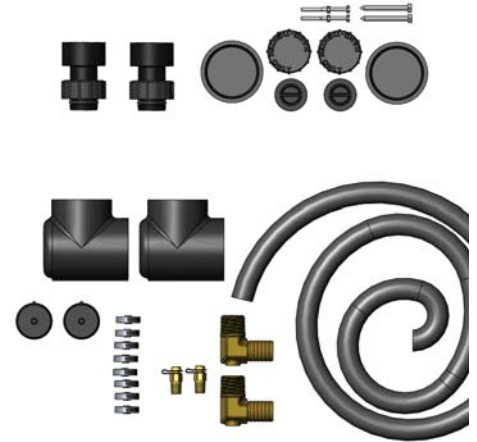

3. Complete heat pump piping. If using a flow sensor (Figure 2), cut a small piece of hose (6" to 8") to connect between the bottom barbed connection at the flow center and the flow sensor. If the package does not use a flow sensor (temperature difference control only), the small piece of hose is not needed. Then, cut the remaining amount of hose as needed for connections to/from the heat pump and the flow center.

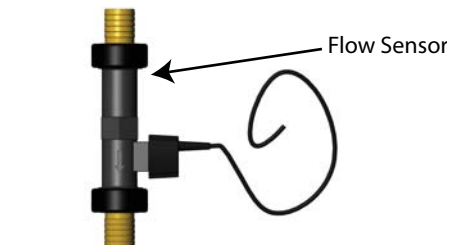
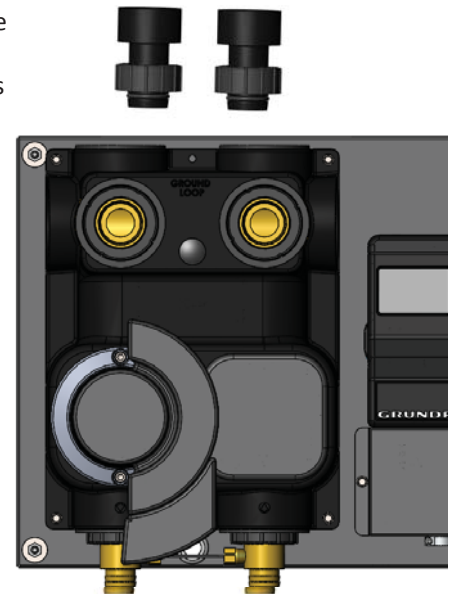

Figure 2: Flow Sensor



WARNING:

- ▶ Make sure that heat pump power is disconnected before proceeding to step #4.

4. Wire low voltage connections. For flow rate control (flow sensor), connect using 18 gauge 4 conductor thermostat wire to terminals ACC, Y2, C, and R from the heat pump to the terminal strip (Figure 3). For temperature control (ΔT), connect ACC, C, and R (Y2 not needed). If included, plug in cable to flow sensor (cable is pre-wired to controller).

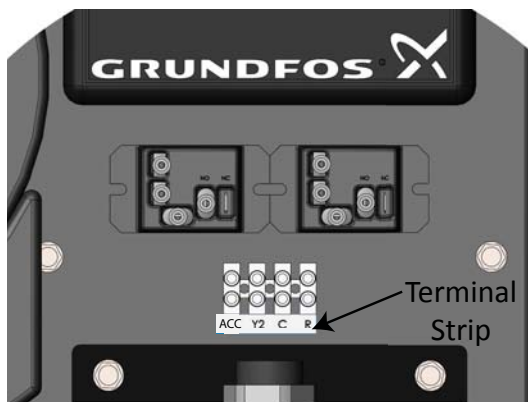

Figure 3: Low Voltage Wiring

Important Note: For heat pumps without an accessory terminal (ACC), connect terminal ACC at the panel mount flow center to the 24VAC side of the compressor contactor coil (see pages 3 & 4).



WARNING:

- ▶ Make sure that heat pump power is disconnected before proceeding to step #5.

5. Complete high voltage wiring to variable speed pump. Run high voltage wiring from the “L” side of the compressor contactor (see CAUTION below) to the pump terminals (refer to Figure 4). Wiring must meet all applicable code requirements, including requirements for wire protection, such as conduit. Wire size must be at least 14 AWG copper conductor.



CAUTION:

- ▶ Do not connect the variable speed pump to the “T” side of the heat pump contactor. The variable speed pump must be powered at all times. After verifying that the heat pump breaker and wire size is sufficient for both the heat pump and the flow center pump(s), connect the variable speed pump to the “L” side of the contactor.

6. Complete high voltage wiring to second pump (if applicable). If a second pump is installed, the second pump must be wired to the Grundfos controller, so that the relay in the controller can engage/disengage the pump based upon heat pump operation (for example, first or second stage operation/flow rate). Refer to Figure 5 for wiring. Run high voltage wiring from the “L” side of the compressor contactor to the Grundfos controller terminals. Run wiring from the controller to the second pump. Wiring must meet applicable code requirements, including requirements for wire protection, such as conduit. Wire size must be at least 14 AWG copper conductor.
7. Complete flushing/purging of ground loop piping. Do not attempt to start the pump(s) until the system has been filled, purged of air, and pressurized.
8. Program Grundfos controller. Refer to the Grundfos UPC-GEO Controller installation manual that ships with the panel mount flow center package for programming details.
9. Test the heat pump/flow center. Verify flow center/heat pump operation in both heating and cooling modes. Controller will display heat pump operating mode (first or second stage), as well as entering/leaving water temperatures and flow rate (if equipped with flow sensor). Record start up data for future reference.

From “L” side of heat pump contactor

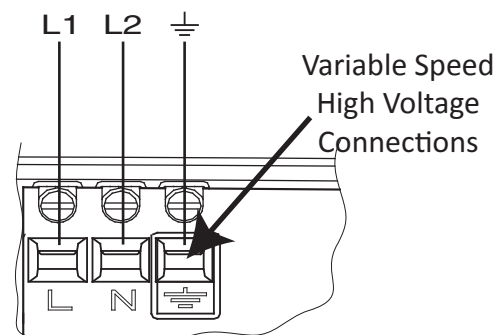

Figure 4: Variable Speed Pump High Voltage Connections

208-230 VAC Input/Output Power to UPS26-99 (2nd pump) for two pump flow centers. Do not connect Magna GEO single pump flow center to this terminal block.

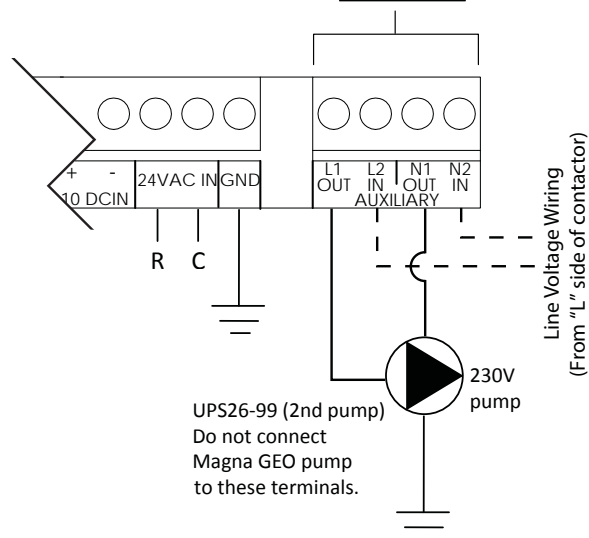

Figure 5: High Voltage to 2nd pump



Important Wiring Notes for Variable Speed Flow Centers: Heat Pumps Without an Accessory Terminal

Many geothermal heat pumps have an accessory terminal (sometimes labeled “A” or “ACC”). One of the purposes for the accessory terminal is for control of a solenoid valve for open loop systems. However, it also affects the operation of the Grundfos UPC-GEO variable speed pump controller. This page and the next will address wiring for systems without an accessory terminal.

The accessory terminal is typically connected to the output from the lockout board to the compressor contactor coil (labeled “CC” in the example below). The compressor contactor is only energized after the anti-short cycle delay, and if there are no lockouts. If the water solenoid is connected between “C” (common) and the heating/cooling thermostat terminal (“Y” or “Y1”), the solenoid will be energized any time there is a thermostat call. Most of the time, this approach works fine. However, if the heat pump is locked out, the water will continue to run even when the compressor is locked out, potentially causing substantial use of water and electricity for the pump. Therefore, using the “CC” connection to engage an accessory ensures that the solenoid valve will not open if the unit is locked out. NOTE: This only applies to solenoid valves without an end switch. Solenoid valves with an end switch must be wired to the thermostat heating/cooling terminals.

A similar issue could occur with the variable speed pump controller. If the heat pump is locked out, and the controller is in temperature difference (ΔT) mode, the thermostat will continue to call, but there will be no ΔT because the compressor is off. Once the heat pump is reset, the controller may not be able to react quickly enough, potentially causing insufficient water flow. When an accessory terminal is used, the control will only be enabled when the compressor contactor is energized.

If the heat pump being installed/serviced does not have an accessory terminal, review Figures 6 and 7 for alternate wiring. In Flow mode, using the thermostat signal for heat pumps without an accessory terminal will not cause a potential low flow problem. However, the pump will run even if the unit is locked out. Therefore, the accessory wiring diagrams below are still recommended for optimal operation even in Flow mode.

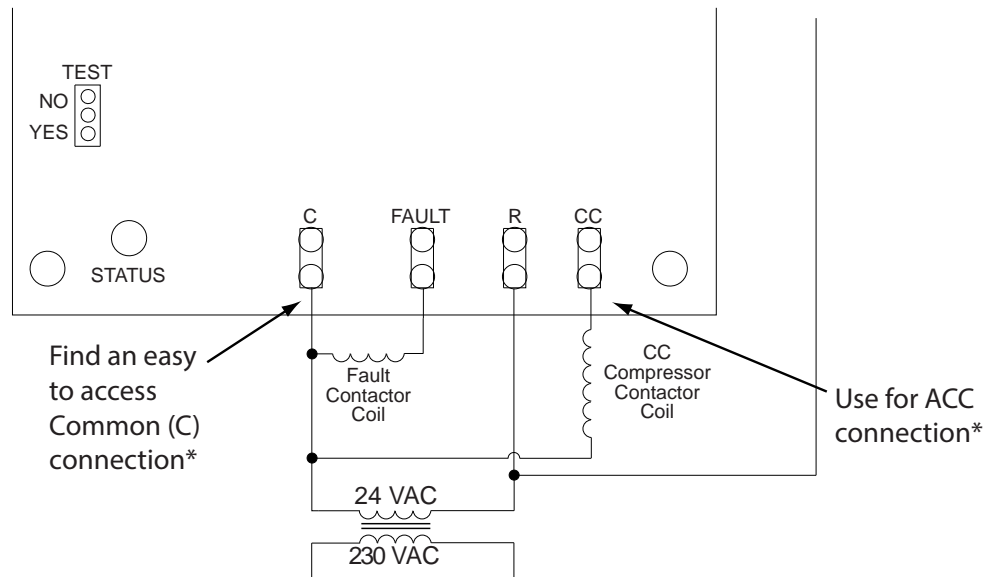

*May require a piggyback spade connector.

Figure 6: Connections for heat pumps with an external compressor contactor, but without an accessory relay

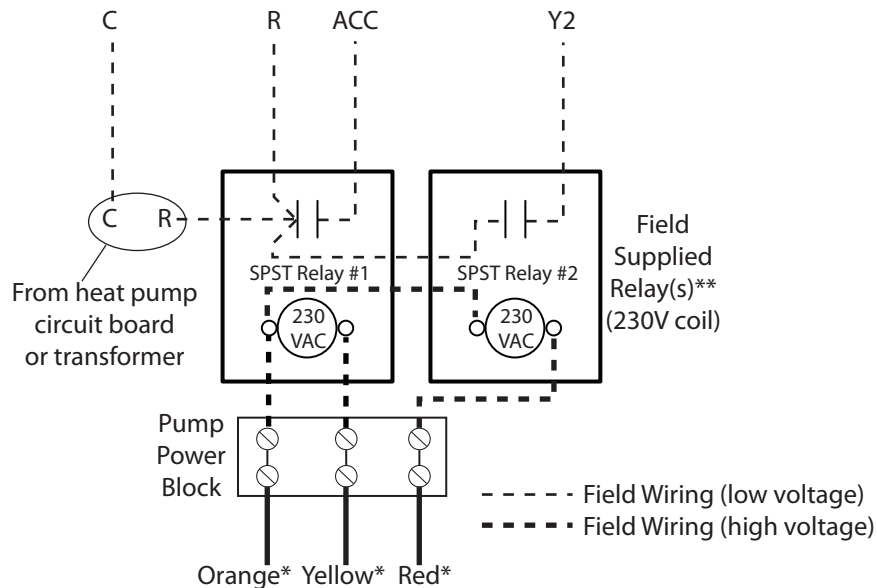

* Not all brands have the same wire colors for the pump power block.

Orange = 230 VAC (common)

Yellow = 230VAC (switched) for 1st stage

Red = 230VAC (switched) for 2nd stage

** Relay #1 needed for temperature difference mode; both relays needed for flow mode.

Figure 7: Connections for heat pumps without an external compressor contactor (compressor relay is on the circuit board), and without an accessory relay

