

GB312-90 Condensing Gas Boiler

Engineering
Submittal
Sheet

Buderus

Boiler Overview



Engineering Specifications

There shall be provided and installed a quantity of ____ Buderus GB312/90 condensing hot water boiler(s), suitable for induced draft firing with natural gas. Boiler(s) shall have a minimum AHRI combustion efficiency rating of 92% at full load.

Boiler(s) shall utilize a siliconized cast aluminum heat exchanger with high quality condensing heating surfaces.

Boiler(s) shall be constructed, tested and labeled in accordance with ASME Section IV and shall bear the ASME stamp. Boilers shall be CSA approved and have an applicable Canadian Registration number.

Heat exchanger shall be labeled for 50psig maximum working pressure rating. An integrated pressure sensor shall ensure minimum and maximum water pressures are not exceeded.

Boiler shall be capable of modulating firing from 33 - 100% of capacity continuously based upon (i) supply and return water temperatures, and/or (ii) outdoor reset computerized control.

Standard equipment shall include a manifold assembly; pressure/temperature gauge, 50psig relief valve, and flow check valve. Leveling feet are included as standard.

Minimal clearances shall be integral to the boiler cabinet design; removable panels shall be used to access heat exchanger, burner components, gas valve and sensors.

Integrated controller shall monitor and control all combustion process functions, control of the boiler water temperature to a value required by the connected components and shall display current water temperatures or fault conditions with changes in operation status. Additional control functions shall include an on/off button, rotary temperature knobs, LED for burner operation and button for fault condition reset.

Independent outdoor temperature reset may be accomplished with the optional AM10 controller; a mounting enclosure shall be included with the provided resistance dependent sensor. Standard communication interface from the AM10 to boiler shall be a two-wire low voltage bus.

GB312-90
Condensing Gas Boiler

Buderus

Performance Data		
	Unit	Value
Boiler sections	–	4
Gas input	MBtu/h	328
Gross rated output	MBtu/h	305
IBR Rating	MBtu/h	265
Boiler horsepower	H.P	9.1
AHRI natural gas combustion efficiency	%	93.4
AHRI natural gas thermal efficiency	%	93.1

General Data		
	Unit	Value
Boiler category	–	Condensing
Heat exchanger construction	–	Aluminum
Maximum allowable working pressure	PSIG	50
Water content	Gallons	4.20
Weight - shipping (approx.)	Lbs	455
Weight - operating (approx.)	Lbs	509
Standard relief valve size (inlet x outlet)	Inch	¾ x 1
Standard relief valve pressure rating (other capacities available upon request)	PSI	50
Venting category	–	IV

Operational Data		
	Unit	Value
Fireside pressure drop	Inch W.C.	0.49
Minimum flow rate	GPM	16.0
Maximum flow rate	GPM	30.0
Maximum supply water temperature	°F	180
Minimum return water temperature	°F	< 54° Supply

Burner Data		
	Unit	Value
Allowable fuels	-	Natural gas
Min Inlet Gas Pressure - NG	Inch W.C.	3.5
Max Inlet Gas Pressure - NG	Inch W.C.	10.5
Motor voltages, gas/oil pressure and modes of operation will vary based upon final burner selection - see burner specification sheet for additional details	-	-

Approval Data	
Approval description	Approval number
Massachusetts Approval #	G1-0409-410
New York MEA #	N/A
CRN #	7834.7C

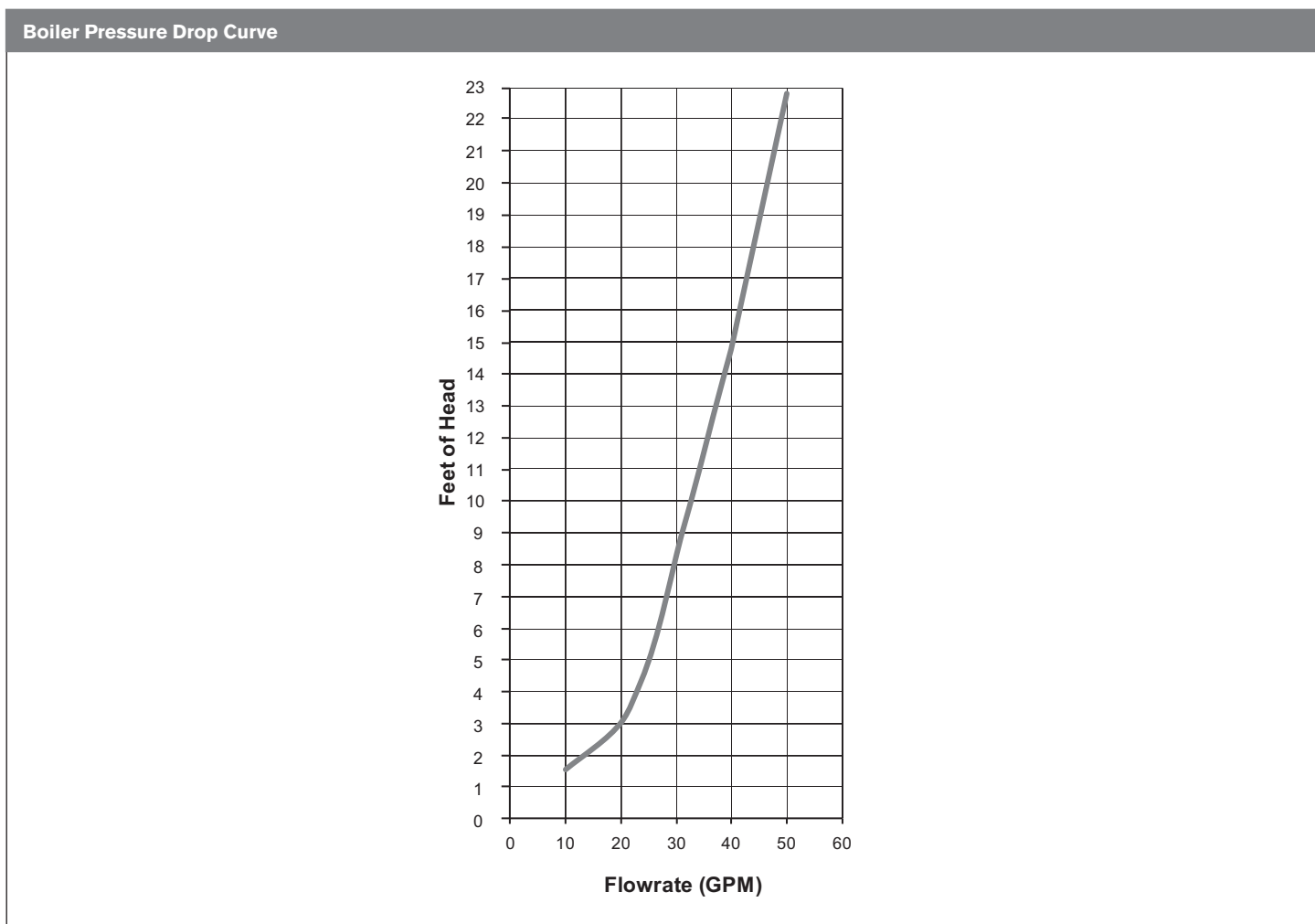

Boiler Dimensions and Connections

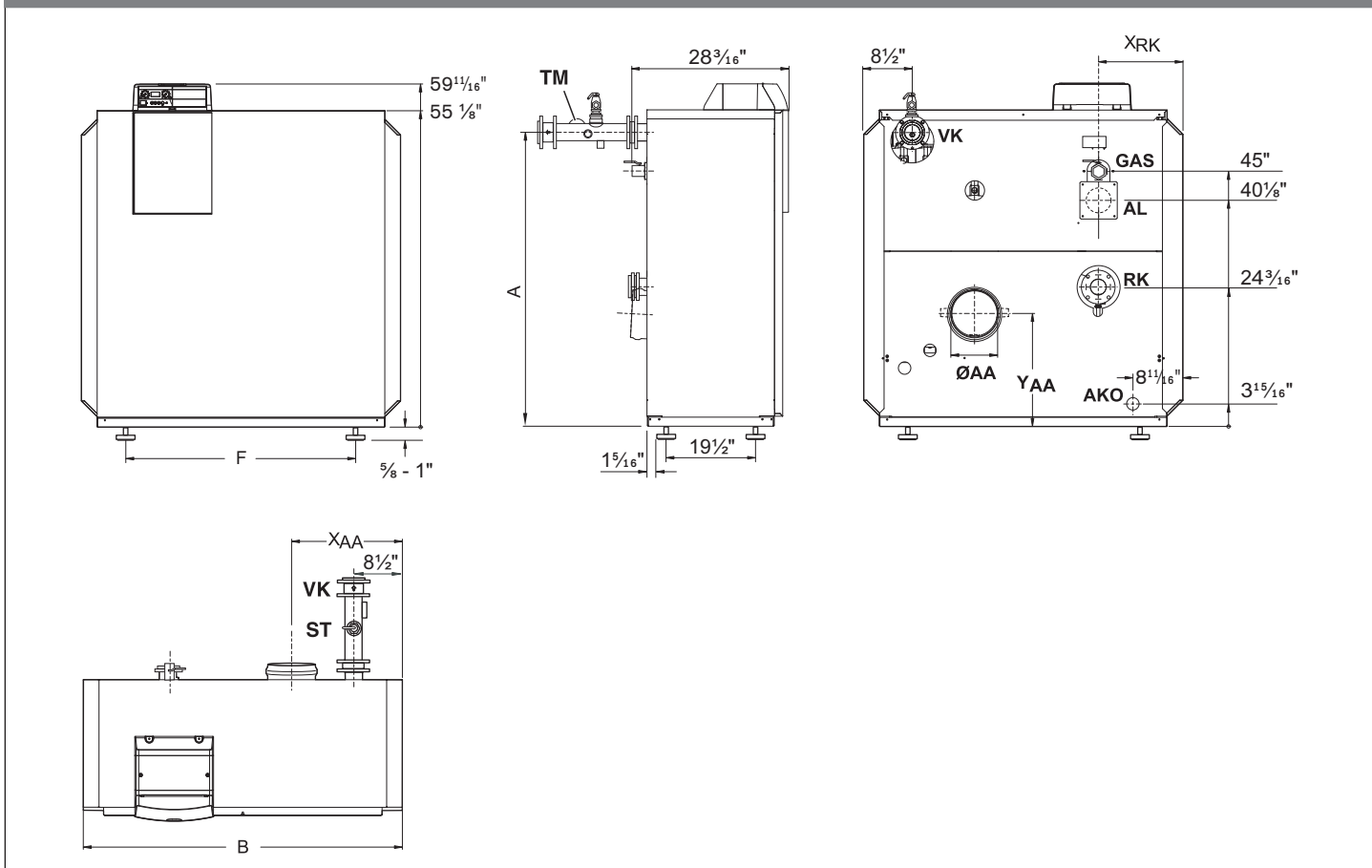

Boiler Dimensions / Connections Data

Item	Description	Unit	Value
RK	Boiler return	Inch	2½
VK	Boiler supply	Inch	2½
AKO	Boiler condensate outlet	Inch	¾
ØAA	Flue gas connection (inside diameter)	Inch	6
AL	Combustion air connection (inside diameter)	Inch	4
GAS	Gas connection size	Inch	1
	Boiler length including outer casing	Inch	28 ³ / ₁₆
	Boiler block height	Inch	55 ¹ / ₈
B	Min. boiler block width	Inch	39 ¹ / ₈

* All dimensions above are within +/- ¼".

B-Kit Assembly with Flow Check Valve

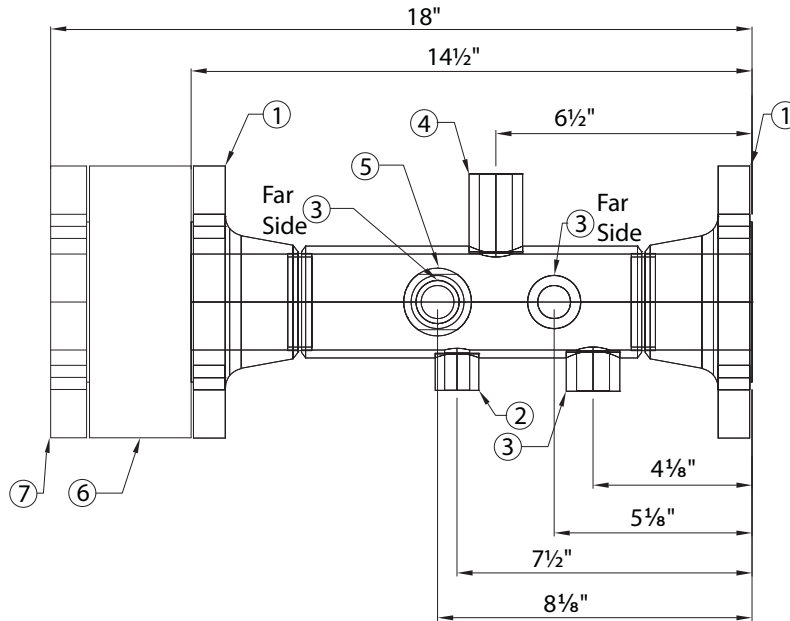

Item	Description	Qty
1	2½" Flange to boiler	2
2	½" Female NPT	1
3	¾" Female NPT	3
4	¾" Female NPT	1
5	1" Female NPT	1
6	2½" Check Valve	1
7	2½" Female NPT Mating Flange to system	1

Boiler Clearances

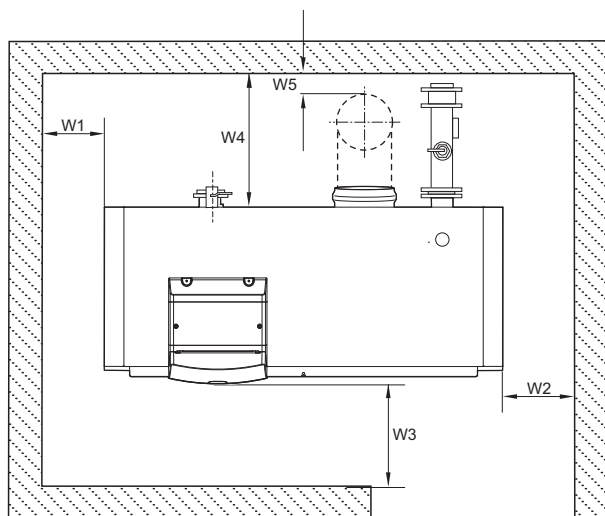

Top View

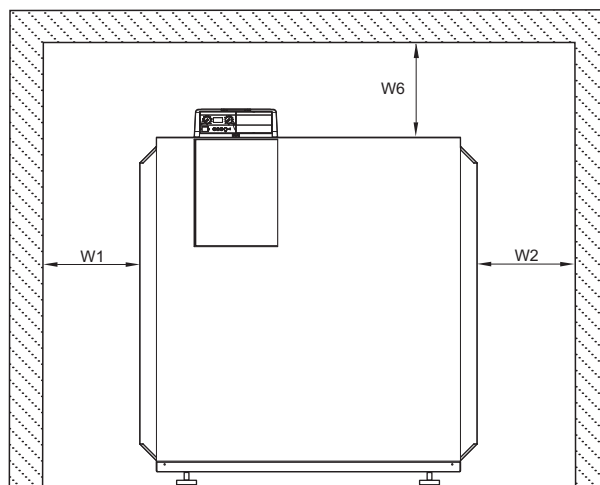

Front View

Description	Unit	Recommended clearance (minimum clearance)
Wall clearance W1	Inch	28 (20)
Wall clearance W2	Inch	28 (20)
Wall clearance W3	Inch	28 (20)
Wall clearance W4	Inch	28 (22)
Wall clearance W5	Inch	14 (6)
Top clearance W6	Inch	24 (12)

DISCLAIMER

Bosch Thermotechnology Corp. makes no warranty or representation, expressed or implied, with respect to the accuracy, completeness, or usefulness of this information, nor assumes any liability with respect to the use of any information contained within this document.