



FHP Manufacturing Co.
 601 N.W. 65th Court
 Fort Lauderdale, FL 33309
 Phone: (954) 776-5471
 Fax: (800) 776-5529
<http://www.fhp-mfg.com>

Hanging Bracket Kit

Assembly Instructions

FHP Hanging Bracket Kit Contents:		
Kit #	930-004	930-006
Used On	EM/EC007-060	EM/EC070
	GT/GS010-042	GT/GS048-070
	EV/ES018-042	EV/ES048-071
	AU025-035	AU049/071
	AP025	AP049/071
Includes:		
Brackets	4	6
Isolators	4	6
Screws	8	12
Also Needed:		
(Furnished by Others)		
Threaded Rod (3/8" max. dia.)		
Washers (1-3/4" min. O.D.)		
Hex Nuts		

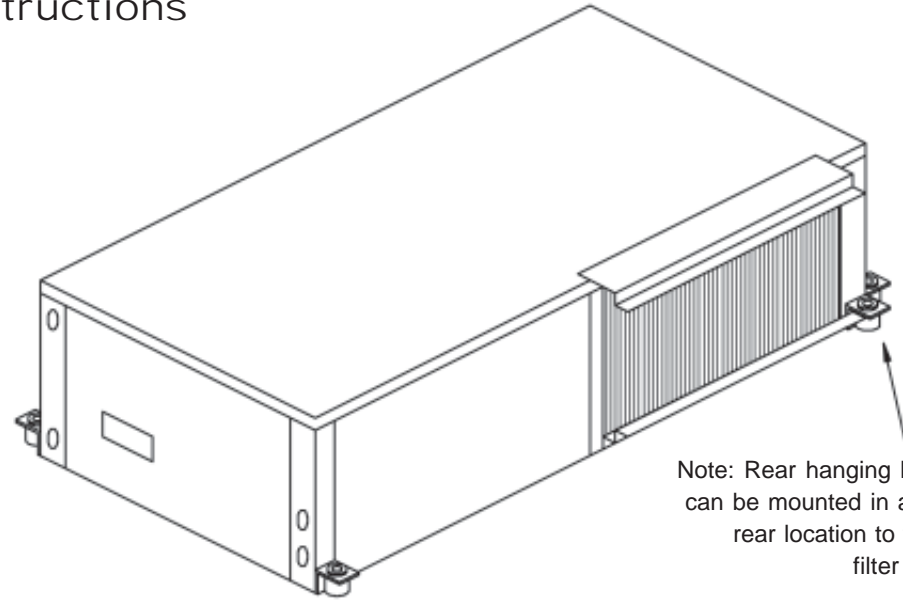
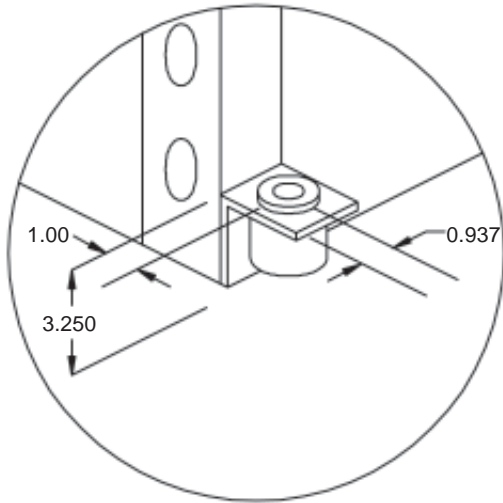

Note: Rear hanging brackets can be mounted in alternate rear location to facilitate filter access.

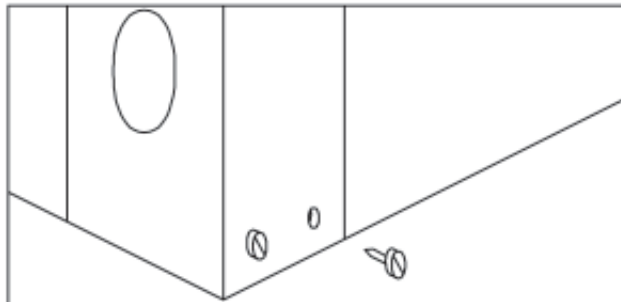

Step 1

Remove factory provided screws (#10 x 3/8") from corner posts at each corner of the unit.

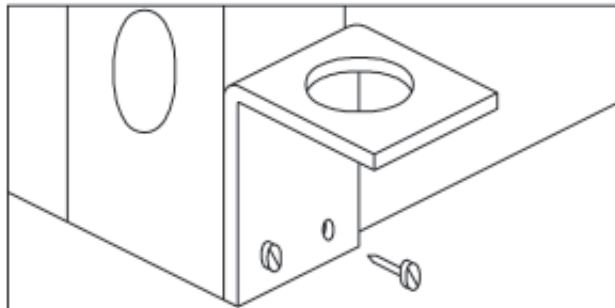

Step 2

Mount brackets to unit corner posts using the screws provided in the hanging bracket kit (#10 x 1/2").
CAUTION: Do not re-use the #10 x 3/8" screws removed from the unit in Step 1 to mount the hanging brackets to the unit.

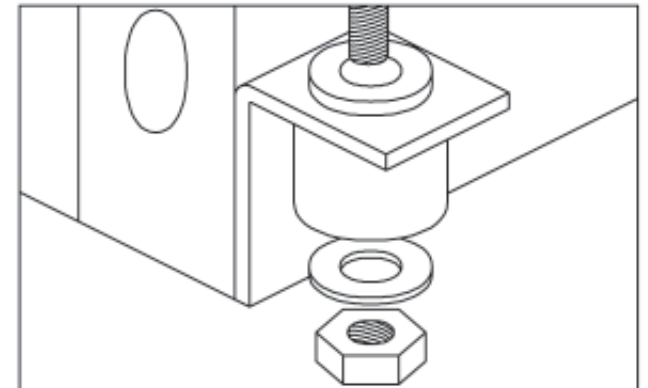

Step 3

Install rubber grommets onto the brackets. Hang the unit and assemble the field provided all-thread rod, nuts and washers onto the brackets.